

---

# **Appendix N**

## Sewer System Analysis (2023)



# **DEXTER WILSON ENGINEERING, INC.**

WATER • WASTEWATER • RECYCLED WATER

CONSULTING ENGINEERS

**SEWER SYSTEM ANALYSIS  
FOR THE  
GUAJOME LAKE ROAD PROJECT  
IN THE CITY OF OCEANSIDE**

March 30, 2023

**SEWER SYSTEM ANALYSIS  
FOR THE  
GUAJOME LAKE ROAD PROJECT  
IN THE CITY OF OCEANSIDE**

March 30, 2023



**Prepared by:**

**Dexter Wilson Engineering, Inc.  
2234 Faraday Avenue  
Carlsbad, CA 92008  
(760) 438-4422**

Job No. 574-021

DEXTER S. WILSON, P.E.  
ANDREW M. OVEN, P.E.  
NATALIE J. FRASCHETTI, P.E.  
STEVEN J. HENDERSON, P.E.  
FERNANDO FREGOSO, P.E.  
KATHLEEN L. HEITT, P.E.

March 30, 2023

574-021

Pasco Laret Suiter & Associates  
1411 San Diego Ave., Suite 100  
San Diego, CA 92110

Attention: Tyler Lawson, P.E., Associate Principal

Subject: Sewer System Analysis for the Guajome Lake Road Project in the City of  
Oceanside

### **Introduction**

This letter-report provides a public sewer system analysis for the Guajome Lake Road project in the City of Oceanside (City). This letter-report will present the recommended onsite sizing of new private sewer infrastructure, as well as sizing of offsite extensions to connect the project to the existing public system. We will also present recommendations of sewer services.

The Guajome Lake Road project is located south of the I-76 along Guajome Lake Road. The project is proposing a residential development that includes 83 single-family units on a 16.8 acre site. A vicinity map for the project is provided in Figure 1.

### **Sewer System Design Criteria**

Sewer system planning and design criteria for the Guajome Lake Road project are based on Section 3 of the City of Oceanside Design and Construction Manual, revised August 1, 2017.

\\ARTIC\DWG\574021\REPORT\GLR\_FIGURE-1\_VCMAP.DWG 3/29/2023 12:20:23 PM LAYOUT:8x11 USER:Donald

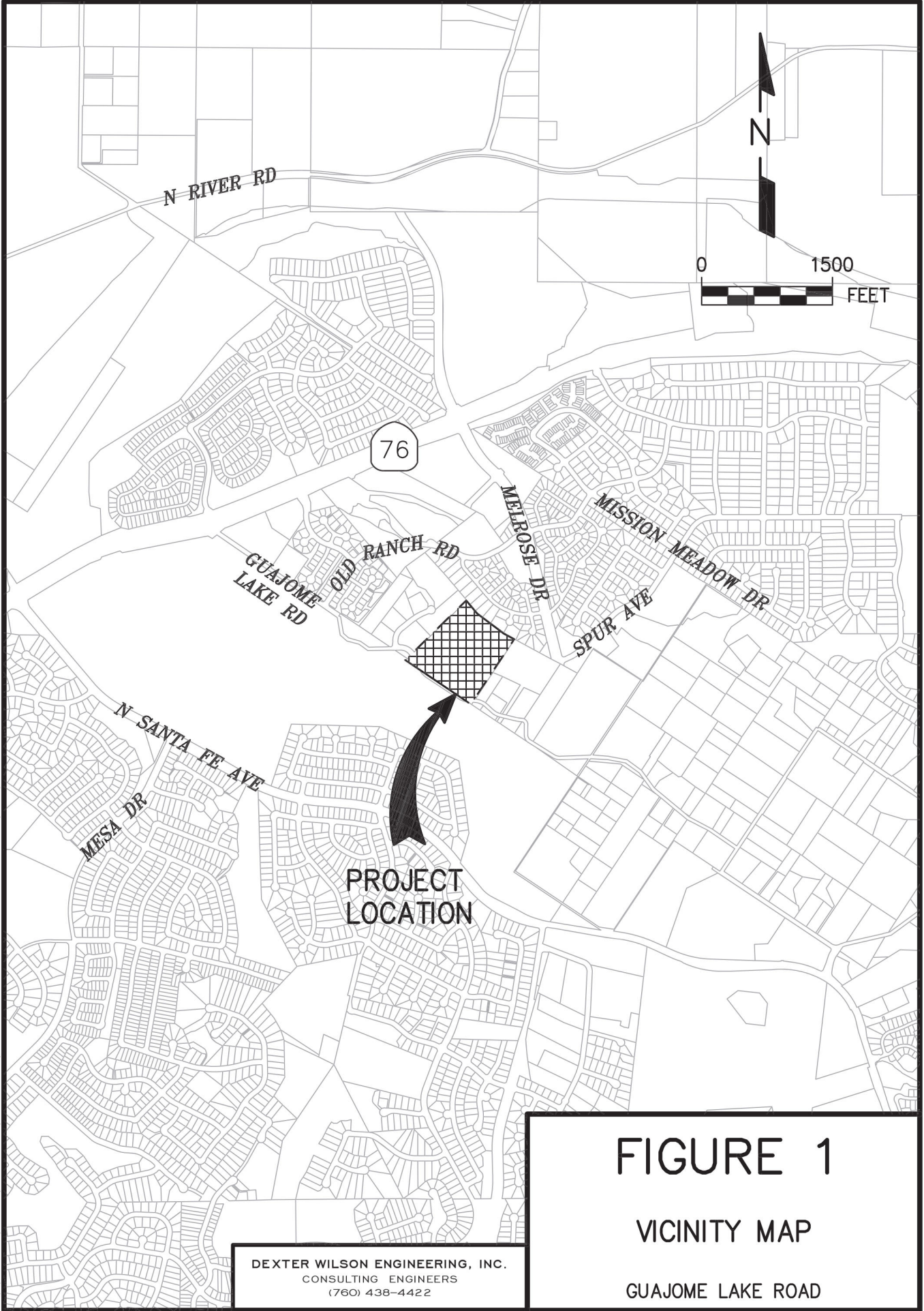

# FIGURE 1

VICINITY MAP

GUAJOME LAKE ROAD

DEXTER WILSON ENGINEERING, INC.  
CONSULTING ENGINEERS  
(760) 438-4422

**Sewer Generation Rates and Peaking Factor.** Section 3 of the City of Oceanside Design and Construction Manual, revised August 1, 2017 was used to develop average sewer flow for the Guajome Lake Road project.

Daily sewer generation rates based on land use are identified in the City’s Design and Construction Manual. These values will be used to analyze the impact of the project’s wastewater generation. The sewer generation rates for the Guajome Lake Road project are presented in Table 1.

<b>TABLE 1 CITY OF OCEANSIDE SEWER GENERATION RATES</b>	
<b>Land Use</b>	<b>Generation Rate</b>
Single Family Residential	170 gpd/DU

For residential developments with a population less than 500 the City’s Design and Construction Manual requires a peaking factor of 3.5 to convert average dry weather flow to peak wet weather flow.

**Manning’s “n”.** The gravity sewer analysis is performed using a computer program which uses the Manning Equation for all of its calculations. The Manning’s “n” used by the computer program is held as a constant for all depths in a circular conduit. The value of Manning’s “n” used for this study is 0.013 which corresponds with the recommended value in the City’s design manual.

**Depth and Velocity of Flow in Gravity Sewers.** Gravity sewer lines are designed to convey peak wet weather flow. Pipes that are 8-inches in diameter and smaller are designed to convey this flow with a maximum depth-to-diameter (d/D) ratio of 0.50. For public gravity sewer lines the design criteria for minimum velocity is 2.0 feet per second at peak flow or a minimum slope of 1.6 percent. For private gravity sewers, the 2019 California Plumbing Code (CPC) states the minimum slope is 1 percent.

### **Estimated Sewer Flows for the Guajome Lake Road Project**

Based on the sewage generation factors presented in Table 1 the estimated average sewer generation for the project is calculated in Table 2.

<b>TABLE 2 GUAJOME LAKE ROAD ESTIMATED AVERAGE SEWER FLOW</b>				
<b>Land Use</b>	<b>Land Use Description</b>	<b>Sewer Generation Factor</b>	<b>Units</b>	<b>Average Sewer Flow, gpd</b>
Residential	Single Family	170 gpd/EDU	83	14,110
<b>TOTAL</b>				<b>14,110 (9.8 gpm)</b>

As previously mentioned, a peaking factor of 3.5 is used for this analysis. Thus, the peak daily sewage flow for the Guajome Lake Road project is 49,385 gpd (34.3 gpm).

### **Existing Sewer System**

Figure 2 presents a schematic of the existing public sewer system in the vicinity of the project. As shown in Figure 2, the existing public sewer system consists of 8-inch diameter sewer lines in Old Ranch Road and Hitching Post Drive. The sewer in Hitching Post Drive continues northwest to a 15-inch trunk sewer in Highway 76. The closest existing public sewer to the project is approximately 2,000 feet away.

\\ARTIC\DWG\574021\REPORT\GLR\_SWR\_FIGURE-2\_EXSEWER.DWG 3/29/2023 12:19:42 PM LAYOUT:11x17 USER:Donald



**FIGURE 2**  
**EXISTING SEWER SYSTEM**  
 GUAJOME LAKE ROAD

DEXTER WILSON ENGINEERING, INC.  
 CONSULTING ENGINEERS  
 (760) 438-4422



### **Proposed Sewer Facilities**

Figure 3 presents a schematic of the proposed sewer facilities required to serve the Guajome Lake Road project. All onsite sewer facilities for the project are proposed to be private. As shown in Table 2, the projected average flow from the site will be 14,110 gpd (9.8 gpm) and the projected peak flow is 49,385 gpd (34.3 gpm).

Each home within the Guajome Lake Road project will also have its own sewer lateral. The minimum sewer lateral size per the City of Oceanside Design and Construction Manual is 4-inches. The maximum capacity of a 4-inch service lateral at a 2 percent slope per the CPC is 216 drainage fixture units (DFUs). Each home within the project will have a drainage fixture unit count of 30 DFUs per the CPC, so a 4-inch lateral is sufficient for each home within the Guajome Lake Road project. Appendix A provides the calculations supporting the sewer lateral sizing.

The project will require a private sewer lift station to deliver flows to the existing 8-inch public sewer line in Old Ranch Road. The lift station will be required to have a minimum capacity of 35 gpm to handle the project peak flow. Estimated Total Dynamic Head (TDH) from the lift station to the existing gravity sewer line is approximately 50 feet at 35 gpm. A submersible vortex pump capable of delivering 70 feet of head at 70 gpm is the initial recommendation for the private sewer lift station. The project proposes to construct approximately 2,000 feet of 3-inch force main, with a maximum velocity of 3.2 fps. See Appendix C for the manufacturers data sheet on this pump. Pipe sizing and pump selection are preliminary and will be further reviewed during the design process.

### **Sewer System Analysis**

To analyze the Guajome Lake Road project's proposed sewer system, an onsite and offsite sewer system analysis was conducted. The analysis of the sewer system is provided in Appendix B. As built of the existing system were used to determine actual slopes. Exhibit A presents the Manhole Diagram for the proposed sewer analysis.



\\ARTIC\DWG\574021\REPORT\GLR\_SWR\FIGURE-3\_PROSEWER.DWG 3/29/2023 1:07:10 PM LAYOUT:11x17 USER:Karam

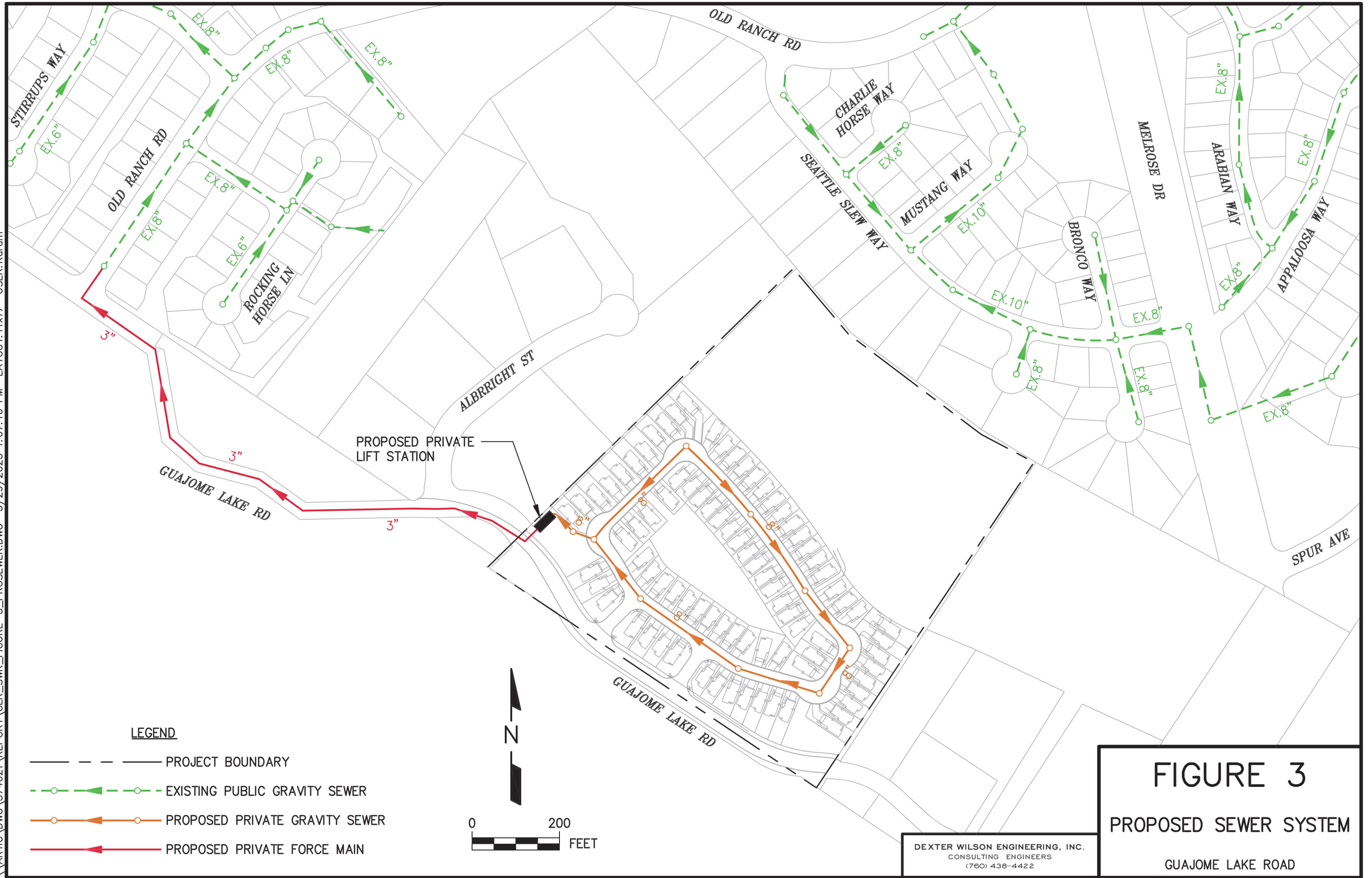

**FIGURE 3**  
**PROPOSED SEWER SYSTEM**  
GUAJOME LAKE ROAD

DEXTER WILSON ENGINEERING, INC.  
CONSULTING ENGINEERS  
(760) 438-4422



The results of the analysis indicate that the maximum depth-to-diameter (d/D) ratio for the Guajome Lake Road project is 0.34 under existing and proposed peak flow conditions. This occurs in the existing 8-inch sewer that connects the sewer line in Hitching Post Drive to the 15-inch trunk sewer in Highway 76. None of the analyzed sewer reaches exceed the maximum d/D design criteria of 0.5.

The velocities in the existing public gravity system range from 1.52 fps to 4.74 fps. The three pipe segments that are below 2 fps are below the City of Oceanside minimum slope of 1.6 percent. The proposed project flows will improve velocities from the existing condition.

The velocities in the proposed private system range from 1.45 fps to 3.07 fps. Where velocities are less than 2 fps, sewers are proposed to have a minimum slope of 1.7% in compliance with both City of Oceanside and California Plumbing Code requirements.

## **Conclusions**

The following conclusions have been made related to providing sewer service to the Guajome Lake Road property.

1. The Guajome Lake Road project will receive sewer service from the City of Oceanside.
2. The existing sewer system near the Guajome Lake Road project is presented in Figure 2. The proposed sewer system for the Guajome Lake Road project is presented in Figure 3.
3. The private onsite sewer system will consist of all 8-inch sewer mains. All individual house laterals shall be 4-inch.
4. The project requires a private sewer lift station to connect the project to the existing public sewer system. The project proposes to construct an approximately 2,000 foot force main along Guajome Lake Road between the project and Old Ranch Road to serve the project. The private sewer lift station will be required to pump the projects peak flow of 49,385 gpd. An initial pump selection is available in Appendix C.

5. An analysis of the existing proposed sewer system was conducted (Appendix B) and the results indicate that the maximum depth-to-diameter ratio that is expected to occur in the proposed sewers is 0.34 during peak flow conditions which is less than the maximum allowable depth-to-diameter ratio of 0.5 for an 8-inch sewer.
6. With the addition of the project, velocities in the existing public system will range from 1.52 fps to 4.74 fps. The proposed project flows will improve velocities in the existing system where they currently don't meet the City of Oceanside criteria. The velocities in the proposed private system range from 1.45 fps to 3.07 fps. Where velocities are less than 2 fps, sewers are proposed to have a minimum slope of 1.7% in compliance with City of Oceanside and California Plumbing Code requirements.
7. The proposed sewer system shall be designed and constructed in accordance with the guidelines, standards, and approved materials of the City of Oceanside.

Thank you for the opportunity to provide sewer system planning services for the Guajome Lake Road project. Please feel free to contact us to further discuss any aspect of the information presented in this letter-report.

Dexter Wilson Engineering, Inc.



Kathleen Heitt, P.E.

KH:ru

Attachments

## **APPENDIX A**

### **SEWER LATERAL SIZING**

Drainage Fixture Units

Project Name Lake Guajome Road

Job Number 574-021  
Date 6/15/2022

Drainage Fixture Units

The basis for the Drainage Fixture Units is the 2019 California Plumbing Code.

DESCRIPTION	PLAN 1A			PLAN 2A			PLAN 3A		
	Public			Public			Public		
	FIXTURE	TOTAL		FIXTURE	TOTAL		FIXTURE	TOTAL	
	QUANTITY	UNITS	FIXTURE	QUANTITY	UNITS	FIXTURE	QUANTITY	UNITS	FIXTURE
	EACH	UNITS		EACH	UNITS		EACH	UNITS	
BATHTUB OR COMB B/S	2	2	4	2	2	4	2	2	4
CLOTHES WASHER, DOM	1	3	3	1	3	3	1	3	3
DISHWASHER, DOMESTIC	1	2	2	1	2	2	1	2	2
DRINKING FOUNTAIN		0.5	0		0.5	0		0.5	0
FOOD WASTE GRINDER, COMM		3	0		3	0		3	0
FLOOR DRAIN		2	0		2	0		2	0
SHOWER	1	2	2	1	2	2	1	2	2
LAVATORY	5	1	5	5	1	5	5	1	5
COMM SINK W/FOOD WASTE		3	0		3	0		3	0
KITCHEN SINK DOMESTIC	1	2	2	1	2	2	1	2	2
LAUNDRY SINK		2	0		2	0		2	0
SERVICE OR MOP BASIN		3	0		3	0		3	0
URINAL		2	0		2	0		2	0
WATER CLOSET 1.6 GRAVITY	3	4	12	3	4	12	3	4	12
WATER CLOSET 1.6 FLUSHOM		4	0		4	0		4	0
TOTAL DRAINAGE FIXTURES			30			30			30

**APPENDIX B**

**SEWER SYSTEM ANALYSIS  
EXISTING AND PROPOSED SEWER SYSTEM**

**SEWER STUDY SUMMARY**

Onsite Sewer Capacity Analysis  
 Dexter Wilson Engineering, Inc.

SHT   1   OF   1    
 REFER TO PLAN SHEET:                     

JOB NUMBER:                     574-021                    

LINE	FROM	IE	TO	IE	LENGTH (ft)	POP. PER D.U.	IN-LINE EDUs	EDUs Served	SEWAGE PER DAY/EDU (gpd/EDU)	AVG. DRY WEATHER FLOW (gpd)	PEAKING FACTOR	PEAK FLOW (gpd)	PEAK FLOW (DESIGN FLOW)		LINE SIZE (inches)	DESIGN SLOPE (%)	DEPTH K' <sup>(1)</sup>	dn (feet)	dn/D <sup>(2)</sup>	C <sub>s</sub> for Velocity <sup>(3)</sup>	VELOCITY (f.p.s.)	Comments
								TOTAL					M.G.D.	C.F.S.								
	1	166.9	2	134.5	294.6	2.5	13.00	13.0	170	2,210	3.500	7,735	0.008	0.012	8	11.0	0.001383	0.02669	0.040	0.0105	2.56	
	1	166.9	3	162.7	209.7	2.5	14.00	14.0	170	2,380	3.500	8,330	0.008	0.013	8	2.0	0.003491	0.04111	0.062	0.0200	1.45	
	3	162.7	4	158.9	210.2	2.5	13.00	27.0	170	4,590	3.500	16,065	0.016	0.025	8	1.8	0.007086	0.05741	0.086	0.0328	1.70	
	4	158.9	5	156.0	160.9	2.5	8.00	35.0	170	5,950	3.500	20,825	0.021	0.032	8	1.8	0.009200	0.06503	0.098	0.0395	1.84	
	5	156.0	6	153.9	120.5	2.5	7.00	42.0	170	7,140	3.500	24,990	0.025	0.039	8	1.7	0.011227	0.07154	0.107	0.0454	1.92	
	6	153.9	7	141.4	229.3	2.5	11.00	53.0	170	9,010	3.500	31,535	0.032	0.049	8	5.5	0.008010	0.06090	0.091	0.0358	3.07	
	7	141.4	8	137.4	231.6	2.5	12.00	65.0	170	11,050	3.500	38,675	0.039	0.060	8	1.7	0.017453	0.08846	0.133	0.0618	2.18	
	8	137.4	2	134.5	167.5	2.5	5.00	70.0	170	11,900	3.500	41,650	0.042	0.064	8	1.7	0.018773	0.09160	0.137	0.0650	2.23	
	2	134.5	9	133.6	46.0	2.5	0.00	83.0	170	14,110	3.500	49,385	0.049	0.076	8	2.0	0.020939	0.09653	0.145	0.0702	2.45	
	9	133.6	LS	132.5	52.8	2.5	0.00	83.0	170	14,110	3.500	49,385	0.049	0.076	8	2.1	0.020292	0.09509	0.143	0.0687	2.50	

Total EDUs
83.0

Min Slope
1.7

Max dn/D
0.14

**SEWER STUDY SUMMARY**

JOB NUMBER: 574-021

Offsite Sewer Capacity Analysis  
Dexter Wilson Engineering, Inc.

SHT 1 OF 1  
REFER TO PLAN SHEET: \_\_\_\_\_

LINE	FROM	IE	TO	IE	LENGTH (ft)	IN-LINE EDUs	EDUs Served	SEWAGE PER DAY/EDU (gpd/EDU)	AVG. DRY WEATHER FLOW (gpd)	PEAKING FACTOR	PEAK FLOW (gpd)	PEAK FLOW (DESIGN FLOW)		LINE SIZE (inches)	DESIGN SLOPE (%)	DEPTH K' (1)	dn (feet)	dn/D <sup>(2)</sup>	C <sub>s</sub> for Velocity <sup>(3)</sup>	VELOCITY (f.p.s.)	Comments
							TOTAL					M.G.D.	C.F.S.								
<b>PROJECT FLOWS</b>						83.00	83.0	170	14,110	3.500	49,385	0.049	0.076	8	2.47	0.018636	0.09128	0.137	0.0647	2.66	Full Flow from Project Force Main
EX.1	131.4	EX.2	123.0	340.0	12.00	12.0	170	2,040	3.500	56,525	0.057	0.087	8	2.47	0.021330	0.09740	0.146	0.0711	2.77	-	
EX.2	123.0	EX.3	121.8	183.0	26.00	38.0	170	6,460	3.500	71,995	0.072	0.111	8	0.66	0.052558	0.15164	0.227	0.1344	1.87	-	
EX.3	128.0	EX.4	113.0	206.4	9.00	47.0	170	7,990	3.500	77,350	0.077	0.120	8	4.27	0.022200	0.09933	0.149	0.0732	3.68	-	
EX.4	113.0	EX.5	111.0	141.0	0.00	47.0	170	7,990	3.500	77,350	0.077	0.120	8	1.42	0.038496	0.12983	0.195	0.1076	2.50	-	
EX.5	111.0	EX.6	107.0	231.0	17.00	64.0	170	10,880	3.500	87,465	0.087	0.135	8	1.73	0.039438	0.13140	0.197	0.1095	2.78	-	
EX.6	107.0	EX.7	96.1	137.4	0.00	64.0	170	10,880	3.500	87,465	0.087	0.135	8	7.91	0.018444	0.09082	0.136	0.0642	4.74	-	
EX.7	96.1	EX.8	95.4	189.8	7.00	71.0	170	12,070	3.500	91,630	0.092	0.142	8	0.40	0.085924	0.19451	0.292	0.1906	1.67	-	
EX.8	95.4	EX.9	95.1	106.3	20.00	91.0	170	15,470	3.500	103,530	0.104	0.160	8	0.28	0.116036	0.22742	0.341	0.2366	1.52	Ties to Ex. 15" Sewer Line in Highway 76	

Total EDUs  
174.0

Min Slope  
0.28

Max dn/D  
0.34

**SEWER STUDY SUMMARY**

JOB NUMBER: 574-021

Offsite Sewer Capacity Analysis (Maximum Expected Pumped Flow)  
Dexter Wilson Engineering, Inc.

SHT 1 OF 1  
REFER TO PLAN SHEET: \_\_\_\_\_

LINE	FROM	IE	TO	IE	LENGTH (ft)	IN-LINE EDUs	EDUs Served	SEWAGE PER DAY/EDU (gpd/EDU)	AVG. DRY WEATHER FLOW (gpd)	PEAKING FACTOR	PEAK FLOW (gpd)	PEAK FLOW (DESIGN FLOW)		LINE SIZE (inches)	DESIGN SLOPE (%)	DEPTH K' (1)	dn (feet)	dn/D <sup>(2)</sup>	C <sub>s</sub> for Velocity <sup>(3)</sup>	VELOCITY (f.p.s.)	Comments
							TOTAL					M.G.D.	C.F.S.								
<b>MAX EXPECTED PUMPED FLOW OF 70 GPM</b>						-	-	-	-	-	100,800	0.101	0.156	8	2.47	0.038038	0.12906	0.194	0.1067	3.29	Full Flow from Project Force Main
EX.1	131.4	EX.2	123.0	340.0	12.00	12.0	170	2,040	3.500	107,940	0.108	0.167	8	2.47	0.040732	0.13354	0.200	0.1121	3.35	-	
EX.2	123.0	EX.3	121.8	183.0	26.00	38.0	170	6,460	3.500	123,410	0.123	0.191	8	0.66	0.090091	0.19930	0.299	0.1972	2.18	-	
EX.3	128.0	EX.4	113.0	206.4	9.00	47.0	170	7,990	3.500	128,765	0.129	0.199	8	4.27	0.036956	0.12726	0.191	0.1046	4.29	-	
EX.4	113.0	EX.5	111.0	141.0	0.00	47.0	170	7,990	3.500	128,765	0.129	0.199	8	1.42	0.064085	0.16755	0.251	0.1547	2.90	-	
EX.5	111.0	EX.6	107.0	231.0	17.00	64.0	170	10,880	3.500	138,880	0.139	0.215	8	1.73	0.062621	0.16561	0.248	0.1521	3.18	-	
EX.6	107.0	EX.7	96.1	137.4	0.00	64.0	170	10,880	3.500	138,880	0.139	0.215	8	7.91	0.029286	0.11368	0.171	0.0889	5.44	-	
EX.7	96.1	EX.8	95.4	189.8	7.00	71.0	170	12,070	3.500	143,045	0.143	0.221	8	0.40	0.134137	0.24562	0.368	0.2627	1.90	-	
EX.8	95.4	EX.9	95.1	106.3	20.00	91.0	170	15,470	3.500	154,945	0.155	0.240	8	0.28	0.173661	0.28285	0.424	0.3172	1.70	Ties to Ex. 15" Sewer Line in Highway 76	

Min Slope  
0.28

Max dn/D  
0.42

**APPENDIX C**

**PRELIMINARY SEWER LIFT STATION  
PUMP SELECTION**

## Pump Performance Datasheet

Customer :	Quote Number / ID :	1694292
Customer ref. / PO :	Model :	SLV.30.A30.80
Tag Number : PRELIMINARY SELECTION	Stages :	1
Service : Vortex - 70gpm @ 70'	Based on curve number :	RC10644
Quantity : 1	Date last saved :	06/13/2022 3:19 PM

Operating Conditions		Liquid	
Flow, rated	: 70.00 USgpm	Liquid type	: Cold Water
Differential head / pressure, rated (requested)	: 70.00 ft	Additional liquid description	:
Differential head / pressure, rated (actual)	: 77.15 ft	Solids diameter, max	: 0.00 in
Suction pressure, rated / max	: 0.00 / 0.00 psi.g	Temperature, max	: 68.00 deg F
NPSH available, rated	: Ample	Fluid density, rated / max	: 1.000 / 1.000 SG
Site Supply Frequency	: 60 Hz		

Performance		Pressure Data	
Speed, rated	: 3535 rpm	Maximum working pressure	: 38.89 psi.g
Efficiency	: 19.05 %		
NPSH required / margin required	: 4.86 / 0.00 ft		
nq (imp. eye flow) / S (imp. eye flow)	: 49 / 188 Metric units		
MCSF	: -		
Head, maximum, rated diameter	: 89.87 ft		
Head rise to shutoff	: 16.49 %		
Flow, best eff. point	: 177.3 USgpm		
Flow ratio, rated / BEP	: 39.48 %		
Diameter ratio (rated / max)	: 100.00 %		
Head ratio (rated dia / max dia)	: 100.00 %		
Solids diameter limit	: 3.15 in		
Cq/Ch/Ce/Cn [ANSI/HI 9.6.7-2010]	: 1.00 / 1.00 / 1.00 / 1.00		
Selection status	: Acceptable		
Curve Tolerance	: ANSI/HI11.6:2017 3B2		
Consult Factory for a different Tolerance			

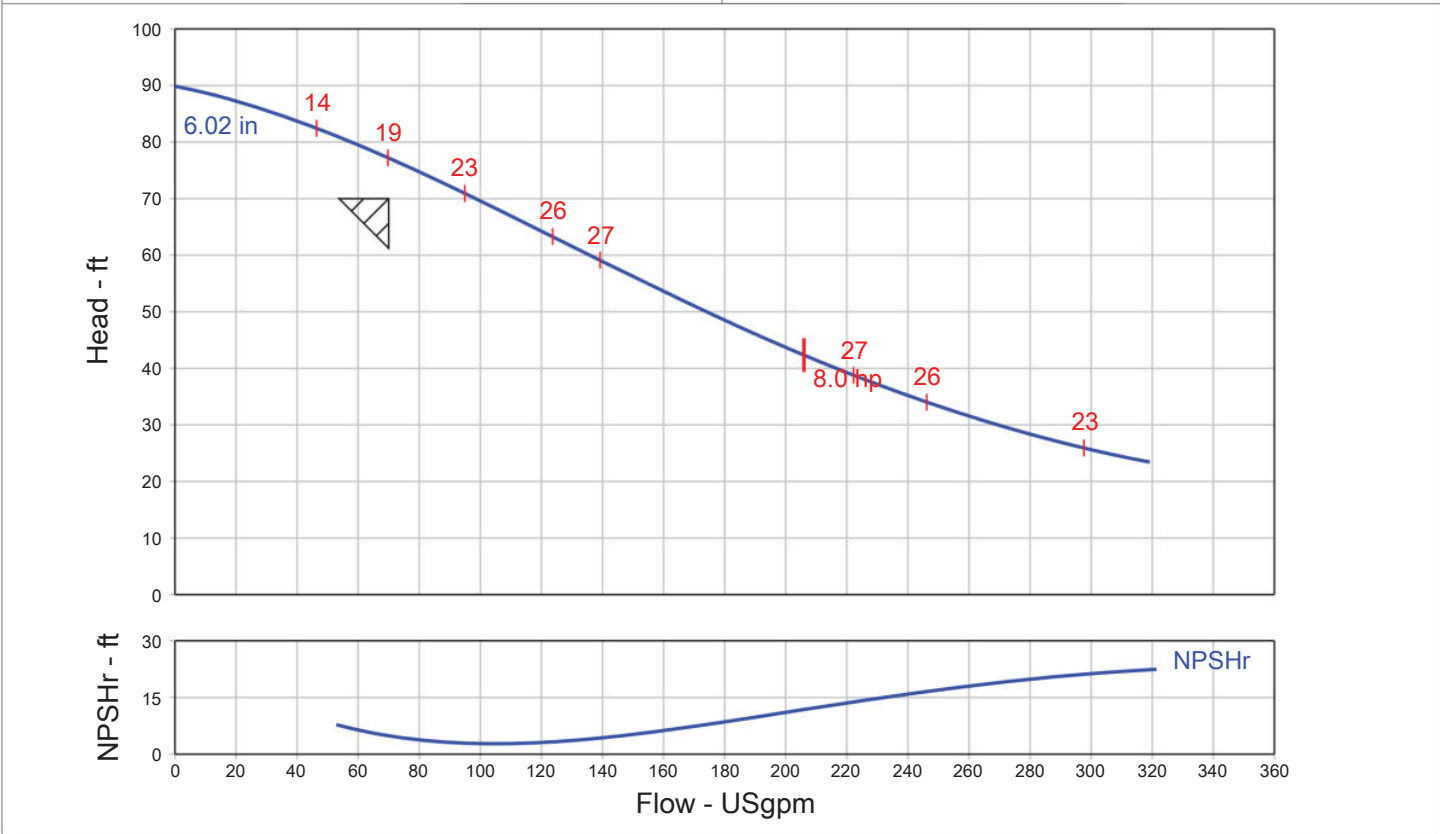

## Grundfos Series SL/SLV Sewage Pump with S-tube®/SuperVortex Impeller

QUOTE NUMBER / ID 1694292	UNIT TAG PRELIMINARY SELECTION	QUANTITY 1
REPRESENTATIVE	SERVICE Vortex - 70gpm @ 70'	DATE
ENGINEER	SUBMITTED BY	DATE
CONTRACTOR	APPROVED BY	DATE
	ORDER #	



**SLV.30.A30.80.EX.2.61R.C**  
**3535 rpm**

Part Number 99030262

Conditions of Service		Pump Data		Motor Data	
Flow	70.00 USgpm	Impeller Diameter	6.02 in	Motor HP	8 HP
Head	70.00 ft	Cooling Jacket	NO	BHP	7.16 HP
Liquid	Cold Water	Max Solid Size	3.15	Enclosure	Explosion Proof
Temperature	68.00 deg F	Efficiency	19.05 %	Voltage	460 V
NPSHr	4.86 ft	Suction	3 in.	Phase	3 Phase
Viscosity	1.00 cP	Discharge	3 in.	Cycle	60
Specific Gravity	1.000 SG			Full Load Amps	11.4
				Locked Rotor Amps	120
				Nema Code Ltr	K

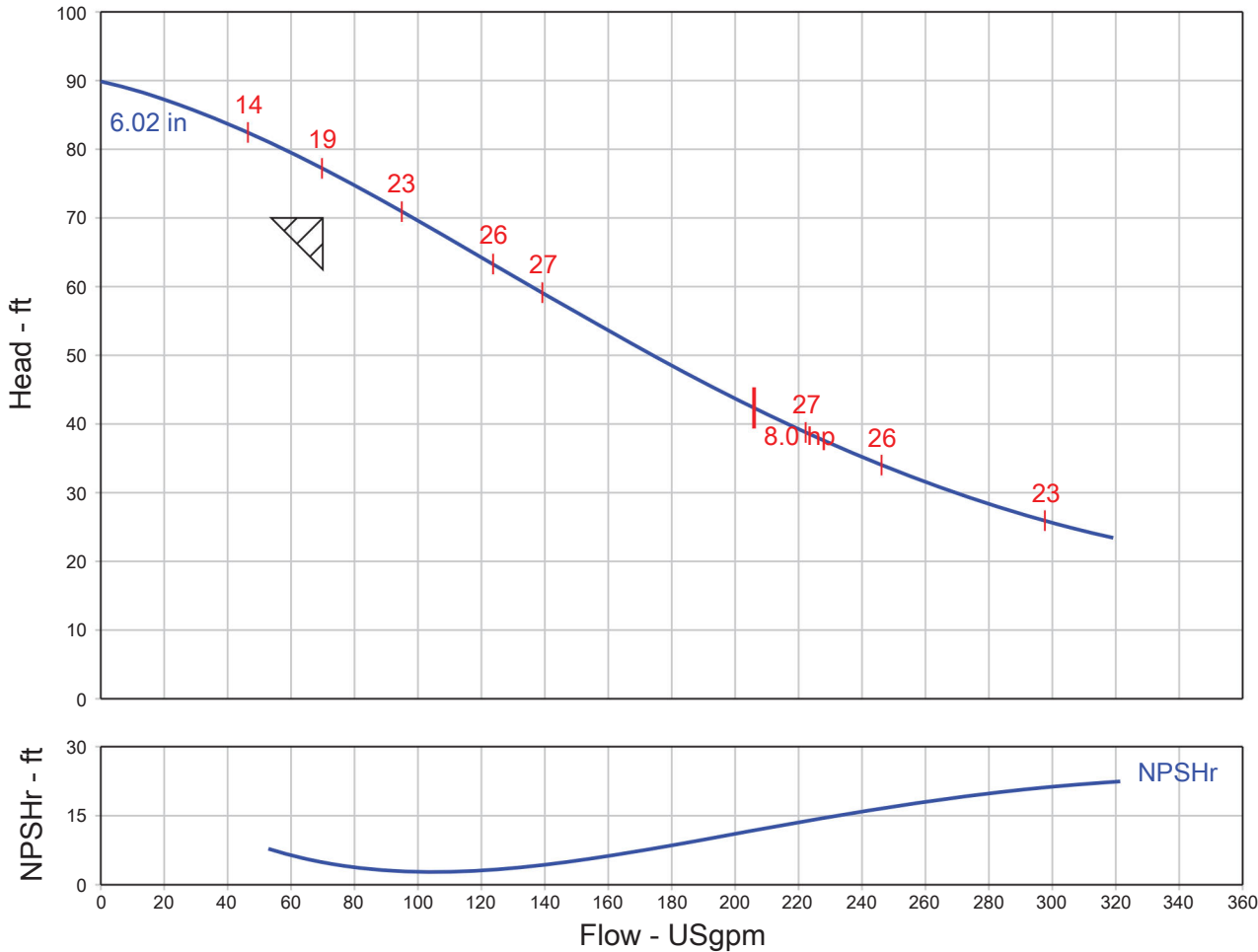

**Grundfos Series SL/SLV Sewage Pump with S-tube®/SuperVortex Impeller**

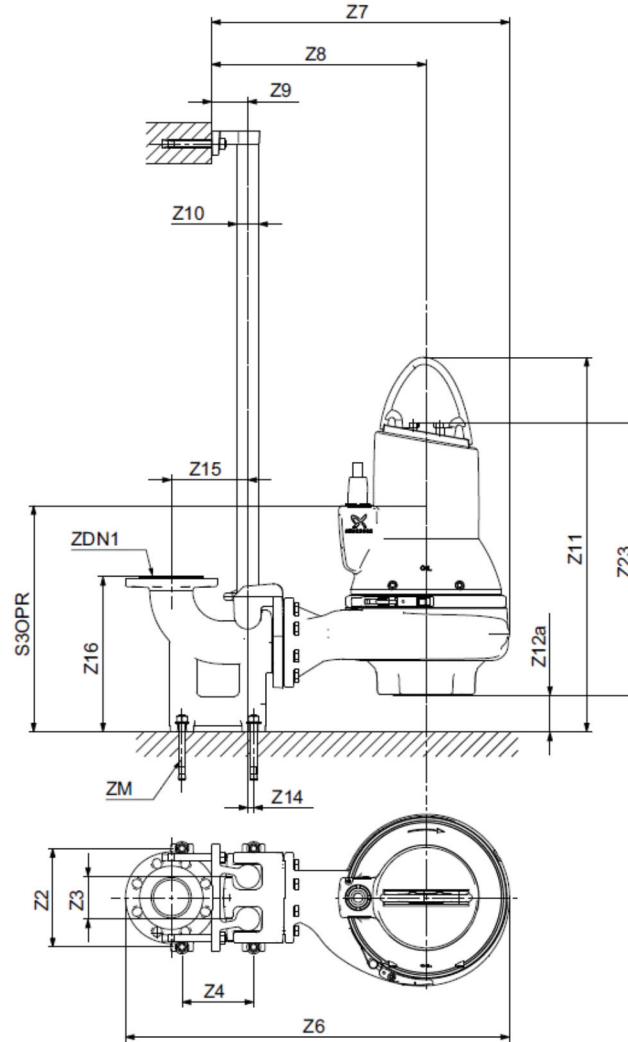

NOT FOR CONSTRUCTION, unless certified and referenced on order

Units	Z2	Z3	Z4	Z6	Z7	Z8	Z9	Z10	Z11	Z12a	Z14	Z15	Z16	ZDN1	ZM	Z23 EX	S3OPR EX
inches	10.20	4.30	8.70	35.00	25.40	18.30	4.30	2.00	34.90	5.40	0.60	8.70	16.30	ANSI 4"	4 X M16	13.60	22.30



\\ARTIC\DWG\574021\REPORT\GLR\_SWR\_EXHIBIT-A\_MH.DWG 3/29/2023 1:09:00 PM LAYOUT:11x17 USER:Karam

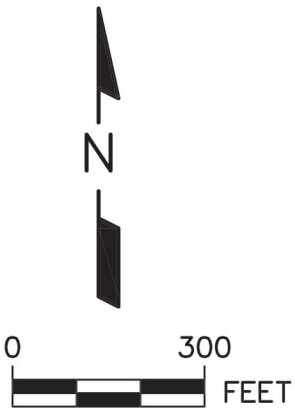
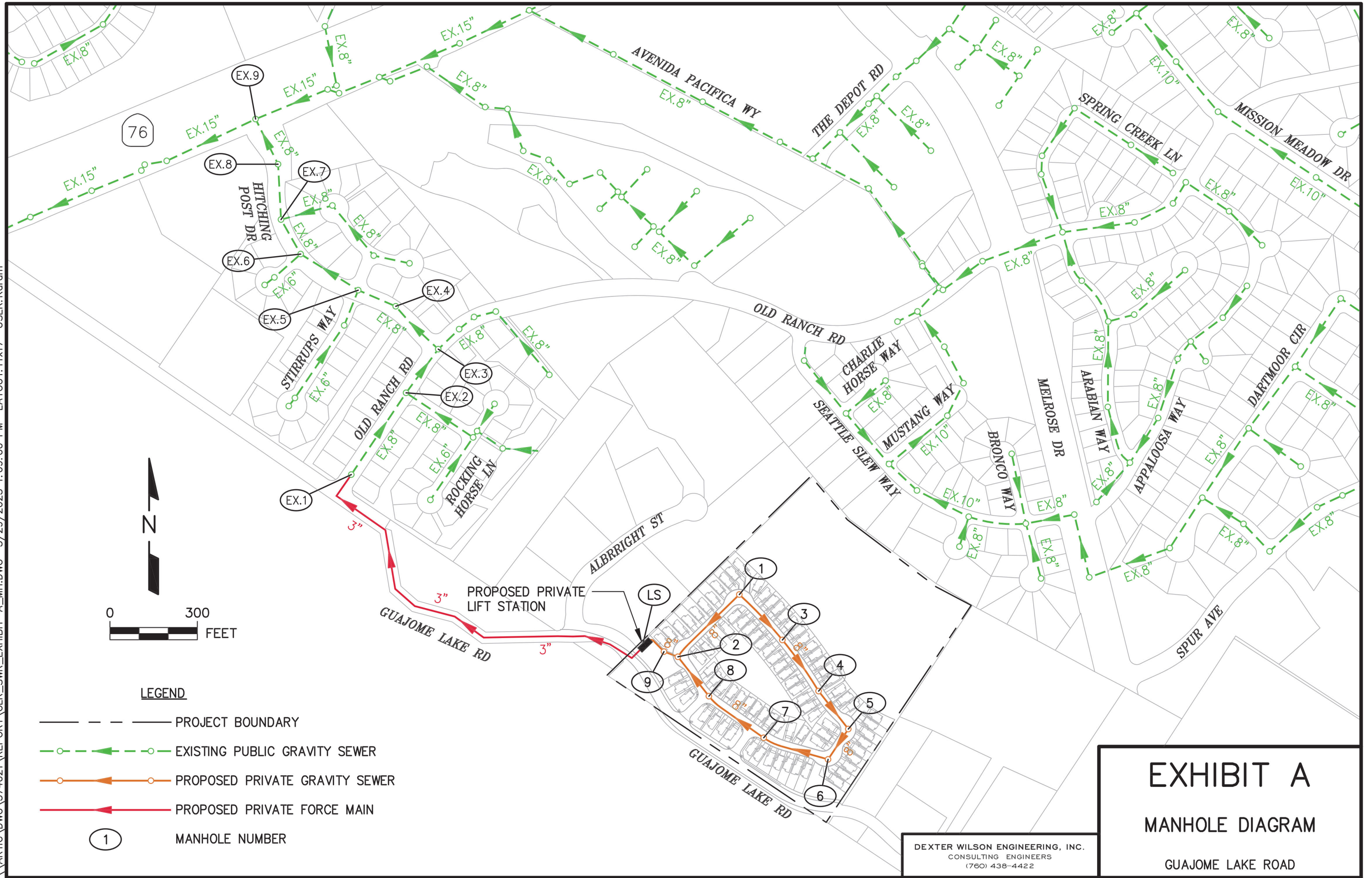

**LEGEND**

- PROJECT BOUNDARY
- - - EXISTING PUBLIC GRAVITY SEWER
- PROPOSED PRIVATE GRAVITY SEWER
- PROPOSED PRIVATE FORCE MAIN
- ① MANHOLE NUMBER

DEXTER WILSON ENGINEERING, INC.  
 CONSULTING ENGINEERS  
 (760) 438-4422

**EXHIBIT A**  
**MANHOLE DIAGRAM**  
 GUAJOME LAKE ROAD

